

# P

## UGELLI A FESSEURE VERTICALI FILTER NOZZLES WITH VERTICAL SLOTS

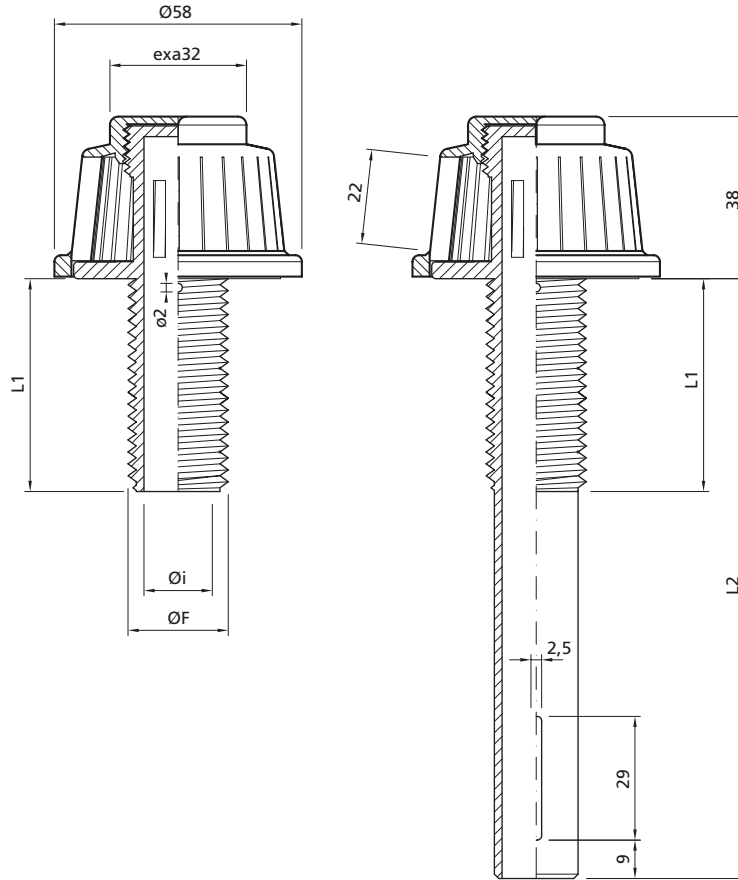

- Adatto per filtrazione a sabbia, antracite
- Di facile pulizia mediante controlavaggio
- Gamma completa di filetti e codoli
- Economico
- Good for sand and anthracite filters
- Easily cleaned by backwash
- Complete set of thread and stem
- Inexpensive



Tipo Type	Fessura Slot width mm	N. Fessure Slots No.	Sezione Area mm <sup>2</sup>
<b>P</b>	0,25	30	165
	0,5	26	286
	1	20	440
	2	18	774
	3	12	684

**Materiale/Material:** PP - PPFV - PVDF

Filetto Thread	ØF mm	Øi mm	Area codolo Stem area mm <sup>2</sup>	L1 mm	L2 mm
1/2"G	20.9	14,5	165	20, 50	50, 140
3/4"G	26.4	16	200	20, 30, 50	50, 80, 100, 120, 140, 160, 200, ..., 400
M20	20	14,5	165	20, 50	50, 140
M24	24	16	200	20, 30, 50	50, 80, 100, 120, 140, 160, 200, ..., 400
M30	30	16	200	30, 50	50, 160, 200, 250, 280
15/16"W	23.5	16	200	20, 30, 50, 120	50, 80, 100, 120, 140, 160, 200, ..., 400
1"W	25.4	16	200	20, 30, 50	50, 80, 100, 120, 140, 160, 200, ..., 400
1.1/4"W	31.75	21,5	363	30, 50, 65	50, 160, 200, 250, 280, 300, ..., 450

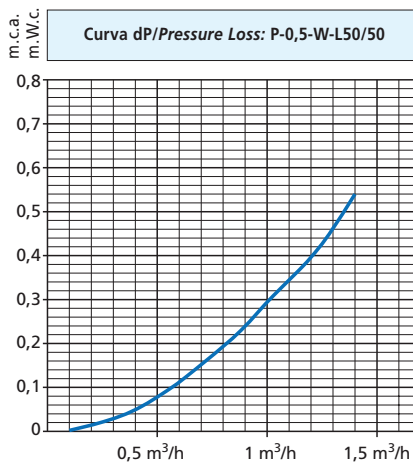
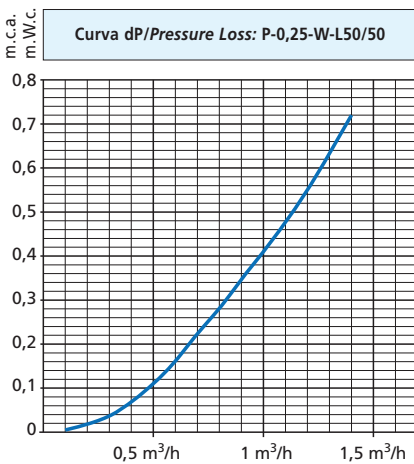

# P5

## UGELLI A FESSURE VERTICALI FILTER NOZZLES WITH VERTICAL SLOTS



- Adatto per distributori di scambiatori a resine e letti misti
- Per montaggio su raccordi filettati commerciali
- Suitable for resin's ion exchanger and mixed beds
- For installation on BSP threaded fittings

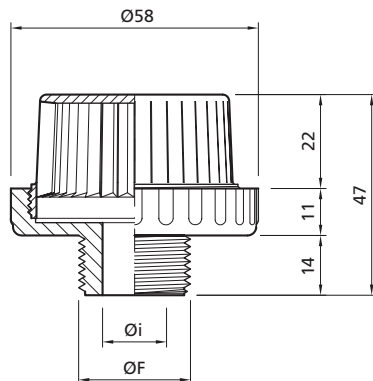

Tipo Type	Fessura Slot width mm	N. Fessure Slots No.	Sezione Area mm <sup>2</sup>
P5	0,25	36	180

Filetto Thread	ØF mm	Øi mm	Area codolo Stem area mm <sup>2</sup>	L1 mm
1/2"G	20.9	15	177	14
3/4"G	26.4	15	177	14
7/8"W	22.2	15	177	14

Materiale/Material: PP - PPFV - PVDF

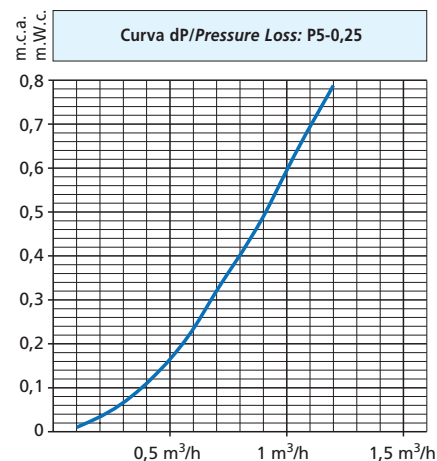

# P6



- Adatto per distributori di scambiatori a resine e letti misti
- Sezione di passaggio inferiore a P5
- Grazie alle maggiori perdite di carico consente una migliore distribuzione del rigenerante
- Suitable for resin's ion exchanger and mixed beds
- Slot area lower than P5
- Better regenerant distribution for higher pressure loss

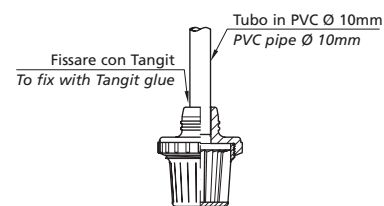
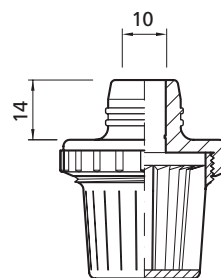
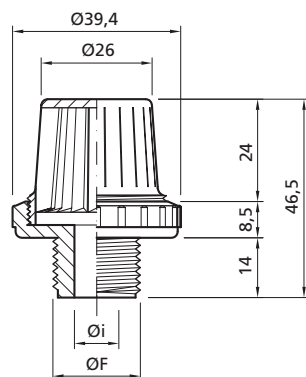

Tipo Type	Fessura Slot width mm	N. Fessure Slots No.	Sezione Area mm <sup>2</sup>
P6	0,25	22	100

Filetto Thread	ØF mm	Øi mm	Area codolo Stem area mm <sup>2</sup>	L1 mm
3/8"G	16.5	10,4	85	14
1/2"G	20.9	10,4	85	14

Materiale/Material: PP - PPFV - PVDF

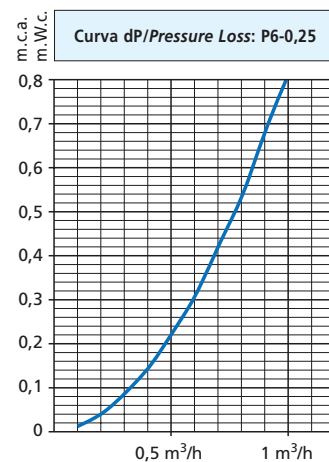

# P7

## UGELLI A FESSURE VERTICALI FILTER NOZZLES WITH VERTICAL SLOTS

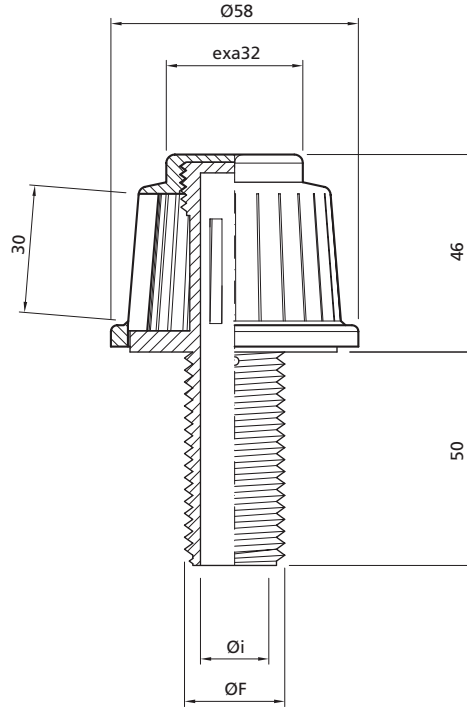

- Adatto per resine a scambio ionico
- Di facile pulizia
- Economico

- Good for ion exchange resins
- Easily cleaned
- Inexpensive

Tipo Type	Fessura Slot width mm	N. Fessure Slots No.	Sezione Area mm <sup>2</sup>
<b>P7</b>	0,25	30	225
	0,5	26	390

Filetto Thread	ØF mm	Øi mm	Area codolo Stem area mm <sup>2</sup>	L1 mm
3/4"G	26.4	17	225	20, 30, 50
15/16"W	23.5	17	225	20, 30, 50

Materiale/Material: PP - PPFV - PVDF

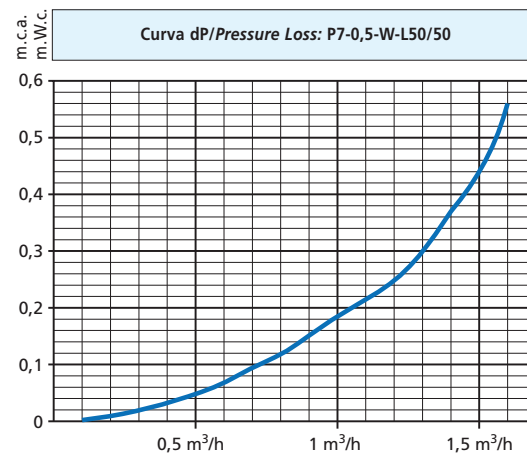
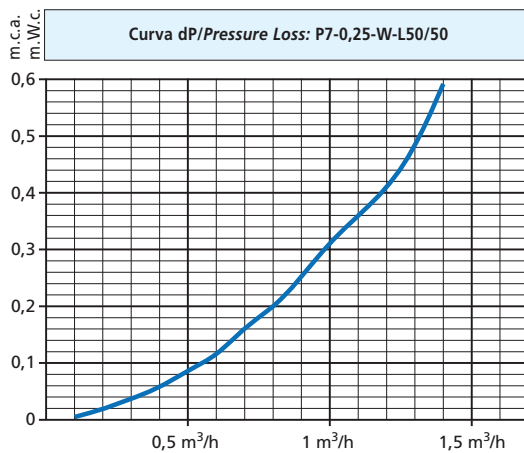

# PDC

## UGELLI A FESSURE VERTICALI FILTER NOZZLES WITH VERTICAL SLOTS

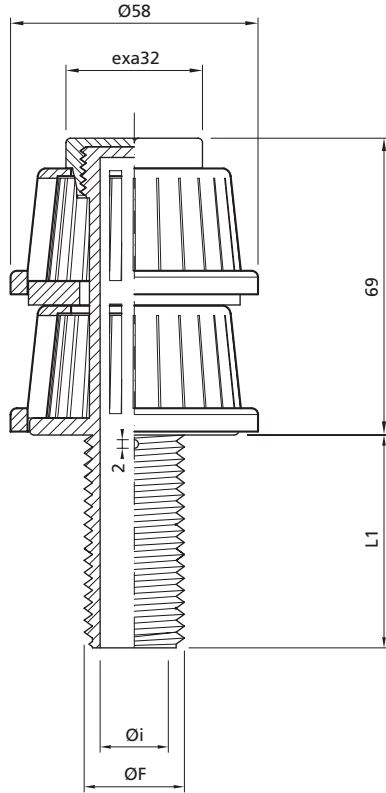

- Non adatto per filtri a sabbia con lavaggio aria
  - Ampia superficie filtrante
  - Sufficientemente robusto
  - Costoso
- 
- Not suitable for sand filters with air backwash
  - Wide filtering area
  - Sufficiently strong
  - Expensive

Tipo Type	Fessura Slot width mm	N. Fessure Slots No.	Altezza Fessure Slots height	Sezione Area mm <sup>2</sup>
PDC	0,25	30 x 2	22	330
	0,5	26 x 2	22	572

Filetto Thread	ØF mm	Øi mm	Area codolo Stem area mm <sup>2</sup>	L1 mm
15/16"W	23.5	17	225	50

Materiale/Material: PP - PPFV - PVDF

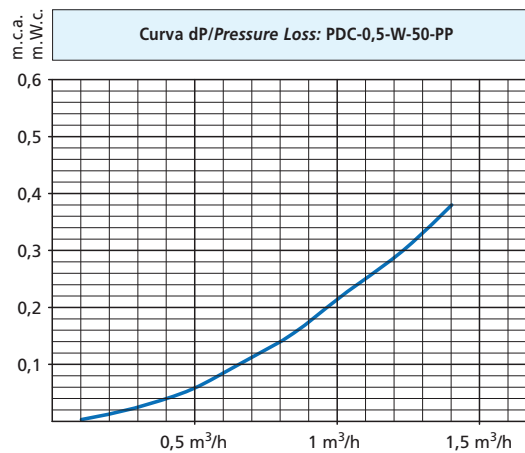
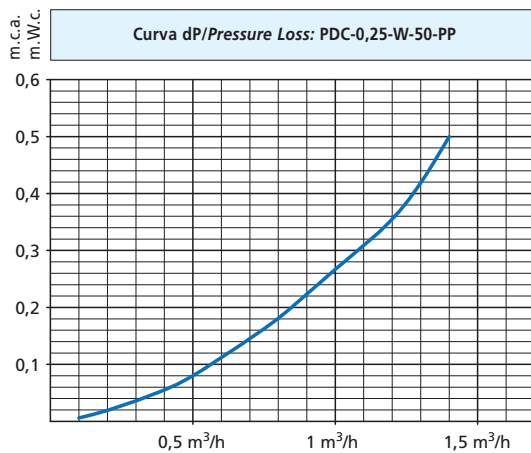

# T

## UGELLI A FESSURE VERTICALI FILTER NOZZLES WITH VERTICAL SLOTS



- Universale
- Ampia superficie filtrante
- Robusto ed economico
- Gamma completa di filetti e codoli
- Multipurpose
- Wide filtering area
- Strong and inexpensive
- Complete set of thread and stem

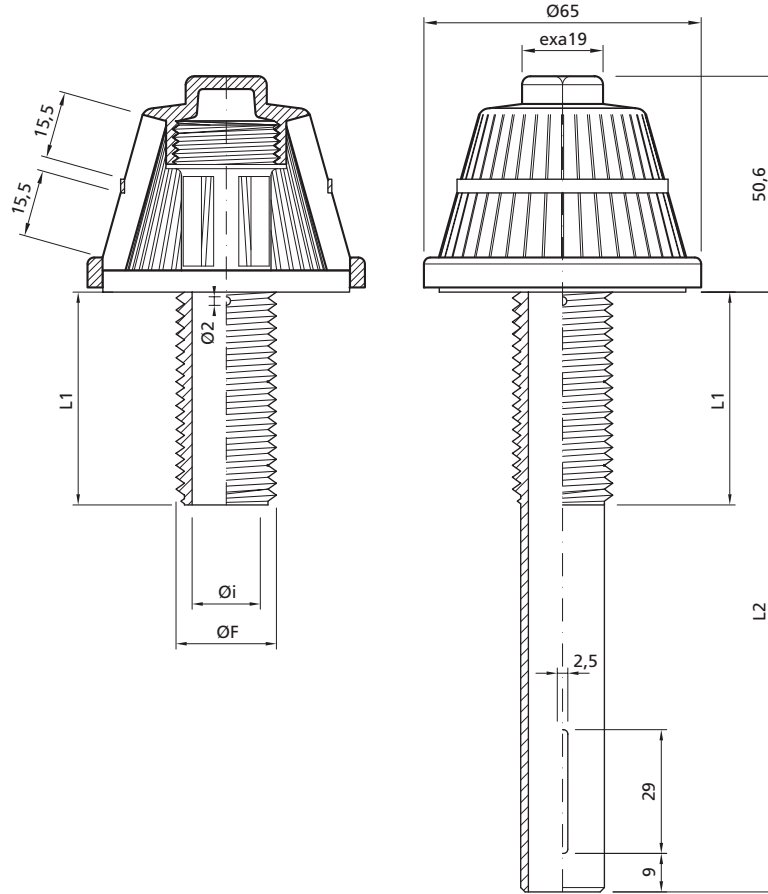

Tipo Type	Fessura Slot width mm	N. Fessure Slots No.	Sezione Area mm <sup>2</sup>
T	0,25	40	310
	0,5	40	620

Materiale/Material: PP - PPFV - PVDF

Filetto Thread	ØF mm	Øi mm	Area codolo Stem area mm <sup>2</sup>	L1 mm	L2 mm
3/4"G	26.4	16	200	20, 30, 50	50, 160, 200, 250, 280
M24	24	16	200	20, 30, 50	50, 80, 100, 120, 140
15/16"W	23.5	16	200	20, 30, 50, 120	50, 80, 100, 120, 140, 160, 200, 250, 280
1"W	25.4	16	200	20, 30, 50	50, 80, 100, 120, 140, 160, 200, 250, 280
1.1/4"W	31.75	21,5	363	30, 50, 65	50, 160, 200, 250, 280, 300, ..., 450

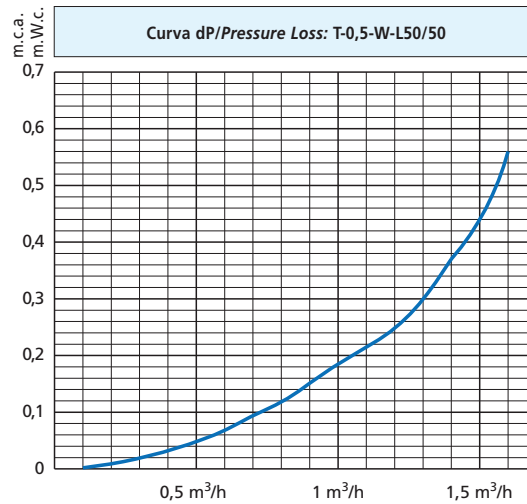
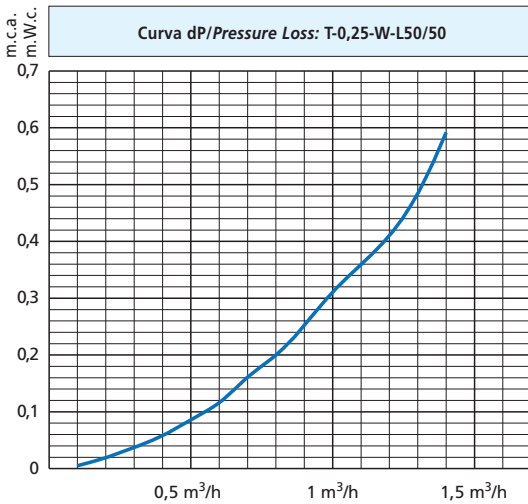

# R

## UGELLI A FESSURE VERTICALI FILTER NOZZLES WITH VERTICAL SLOTS



- Universale, anche con fessura speciale per carboni attivi
- Ampia superficie filtrante
- Molto robusto
- Gamma completa di filetti e codoli
- *Universal, with special slot for activated carbons*
- *Wide filtering area*
- *Very strong*
- *Complete set of thread and stem*

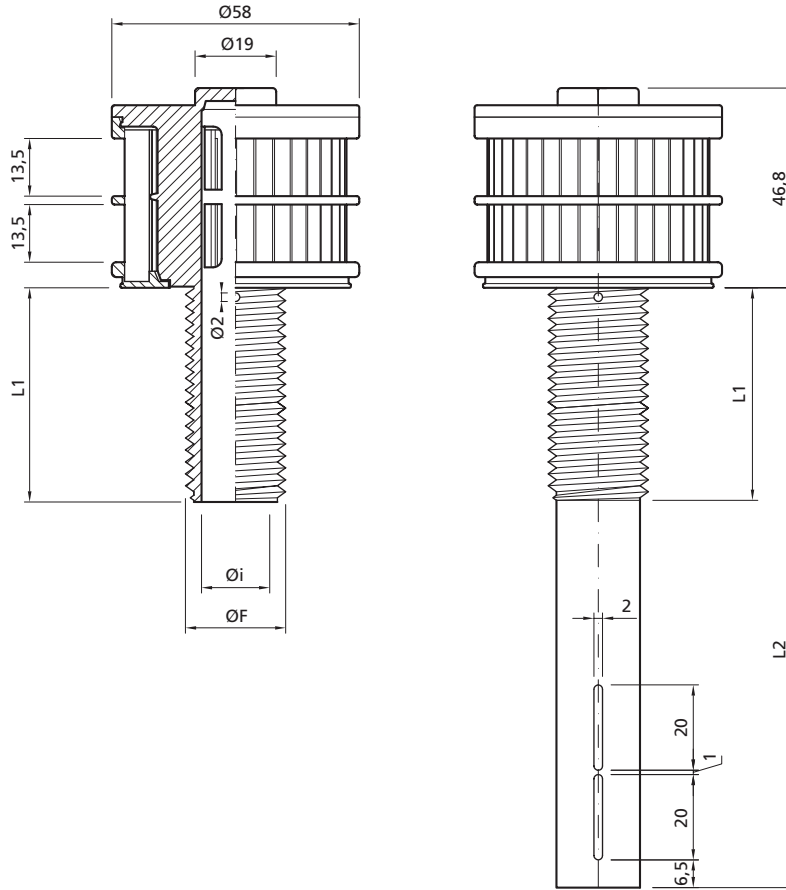

Tipo Type	Fessura Slot width mm	N. Fessure Slots No.	Sezione Area mm <sup>2</sup>
<b>R</b>	0,25	40	270
	0,35	36	340
	0,5	36	486
	0,6	36	583

Materiale/Material: PP - PPFV - PVDF

Filetto Thread	ØF mm	Øi mm	Area codolo Stem area mm <sup>2</sup>	L1 mm	L2 mm
3/4"G	26.4	17	225	20, 30, 50	50, 80, 100, 120, 140, 160, 200, .... ,400
M24	24	17	225	20, 30, 50	50, 80, 100, 120, 140, 160, 200, .... ,400
15/16"W	23.5	17	225	20, 30, 50	50, 80, 100, 120, 140, 160, 200, .... ,400
1"W	25.4	17	225	20, 30, 50	50, 80, 100, 120, 140, 160, 200, .... ,400
1.1/4"W	31.75	21,5	363	30, 50	50, 160, 200, 250, 280, 300, .... ,450

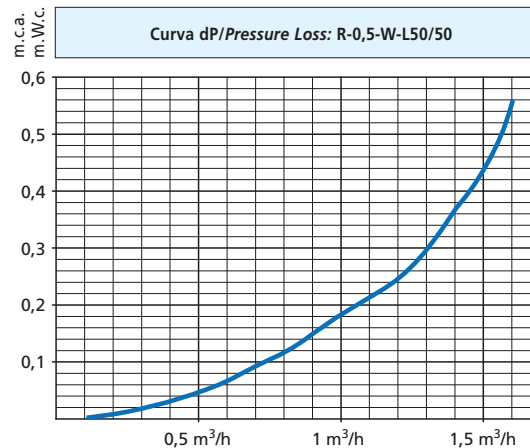
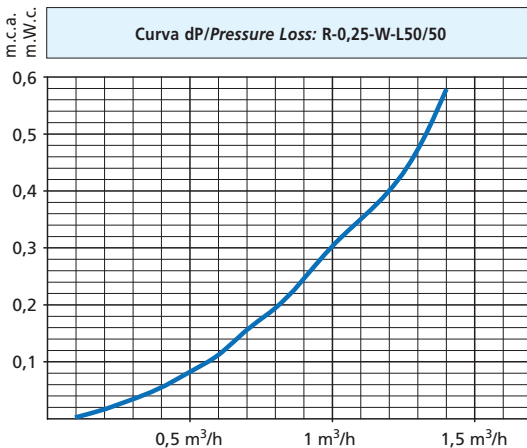

# B

## UGELLI A FESSURE VERTICALI FILTER NOZZLES WITH VERTICAL SLOTS



- Particolarmente indicato per diffusione aria in Bio tunnel
- Suitable for air distribution in Bio tunnel

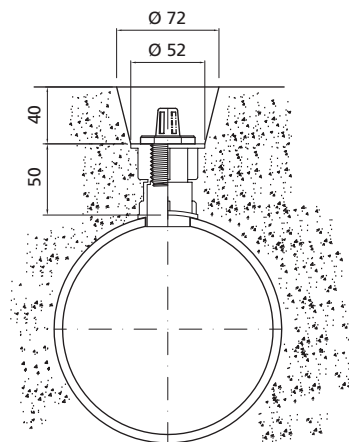
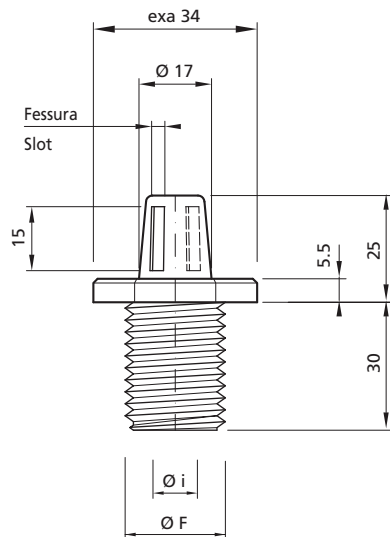

Tipo Type	Fessura Slot width mm	N. Fessure Slots No.	Sezione Area mm <sup>2</sup>
<b>B</b>	4	2	120

Filetto Thread	ØF mm	Øi mm	Area codolo Stem area mm <sup>2</sup>	L1 mm
15/16"W	23.5	19	225	30

<b>Materiale/Material:</b>	PP - PPFV - PVDF
----------------------------	------------------

# V



- Sezione di passaggio molto bassa per distributori di reagenti in colonne a resine
- Low slot area, for regenerant distribution in ion exchange resin columns

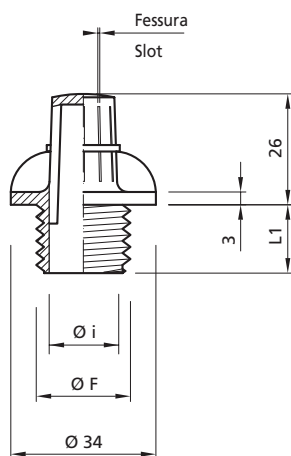

Tipo Type	Fessura Slot width mm	N. Fessure Slots No.	Sezione Area mm <sup>2</sup>
<b>V</b>	0,25	10	34
	0,60	10	82

Filetto Thread	ØF mm	Øi mm	Area codolo Stem area mm <sup>2</sup>	L1 mm
7/8"W	22,2	16	200	16

<b>Materiale/Material:</b>	PP - PPFV - PVDF
----------------------------	------------------

