

D4.7

UGELLI A FESSURE ORIZZONTALI FILTER NOZZLES WITH HORIZONTAL SLOTS

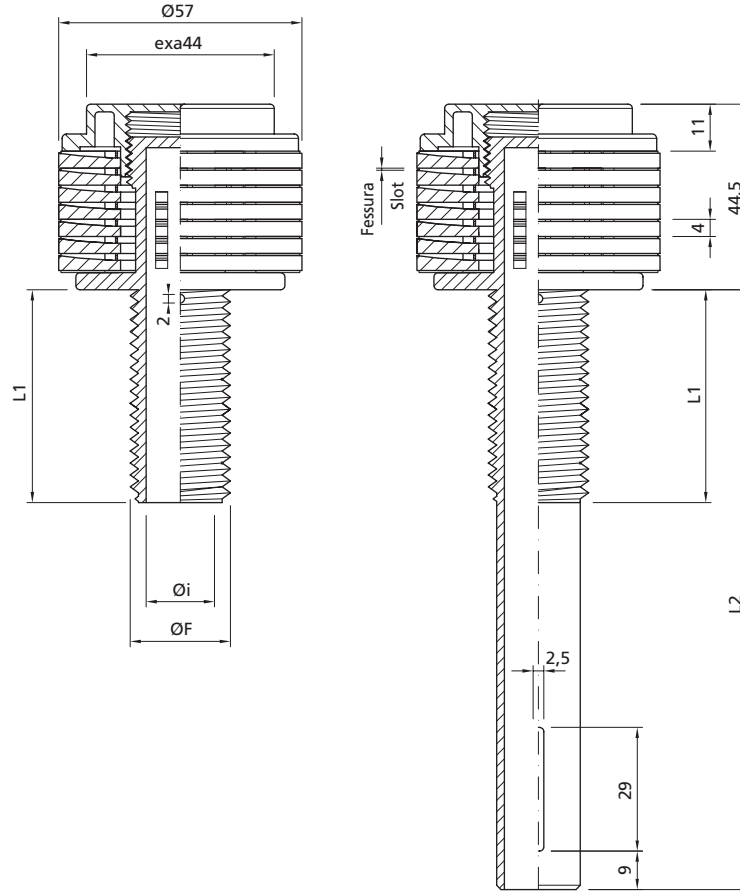

- Indicato per acque pulite
- Per resine a scambio ionico
- Molto robusto
- Suitable for clean water
- For ion exchange resins
- Very strong



Tipo Type	Fessura Slot width mm	N. Fessure Slots No.	Sezione Area mm ²
D4.7	0,15	8	215
	0,25	8	358
	0,5	8	716
	2	5	1790

Materiale/Material: PP - PPFV - PVDF

Filetto Thread	ØF mm	Øi mm	Area codolo Stem area mm ²	L1 mm	L2 mm
1/2"G	20.9	14,5	165	20,50	50, 140
3/4"G	26.4	16	200	20, 30, 50	50, 80, 100, 120, 140, 160, 200, ..., 400
M20	20	14,5	165	20, 50	50, 140
M24	24	16	200	20, 30, 50	50, 80, 100, 120, 140, 160, 200, ..., 400
M30	30	16	200	30, 50	50, 160, 200, 250, 280
15/16"W	23.5	16	200	20, 30, 50, 120	50, 80, 100, 120, 140, 160, 200, ..., 400
1"W	25.4	16	200	20, 30, 50	50, 80, 100, 120, 140, 160, 200, ..., 400
1.1/4"W	31.75	21,5	363	30, 50, 65	50, 160, 200, 250, 280, 300, ..., 450

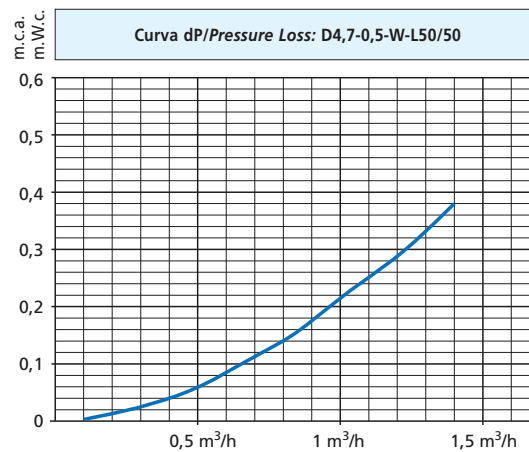
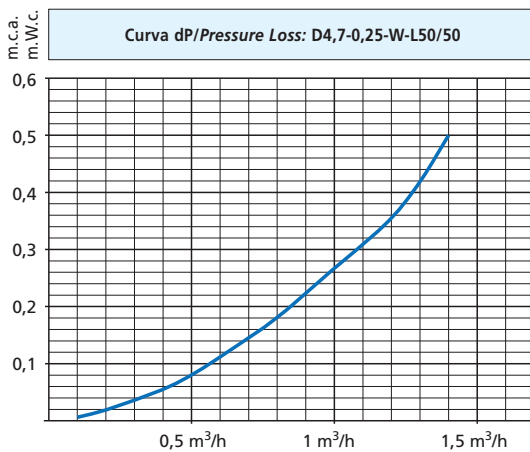

D4.9

UGELLI A FESSURE ORIZZONTALI FILTER NOZZLES WITH HORIZONTAL SLOTS

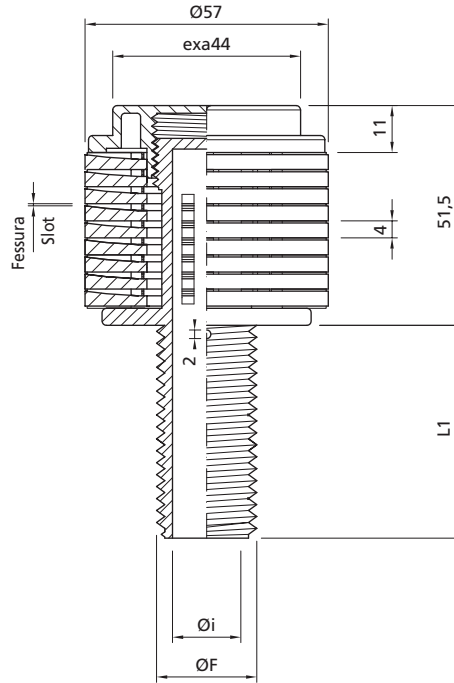

- Indicato per acque pulite
- Per resine a scambio ionico
- Basse perdite di carico / Ampia superficie filtrante
- Molto robusto
- Suitable for clean water
- For ion exchange resins
- Low pressure loss / High filtering area
- Very strong

Tipo Type	Fessura Slot width mm	N. Fessure Slots No.	Sezione Area mm ²
D4.9	0,15	11	268
	0,25	10	448
	0,5	10	895
	2	6	2148

Filetto Thread	ØF mm	Øi mm	Area codolo Stem area mm ²	L1 mm	L2 mm
3/4"G	26.4	17	225	20, 30, 50	
15/16"W	23.5	17	225	20, 30, 50	

Materiale/Material: PP - PPFV - PVDF

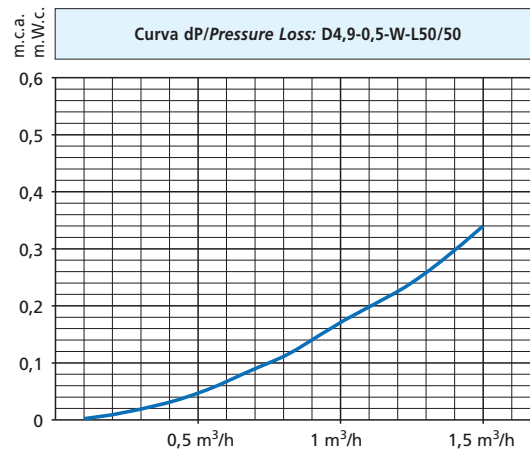
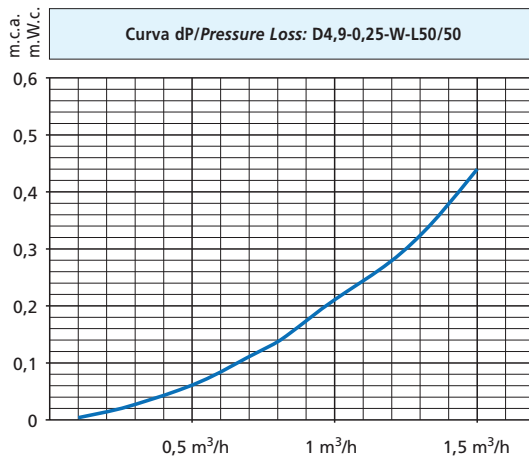

D4.15

UGELLI A FESSURE ORIZZONTALI FILTER NOZZLES WITH HORIZONTAL SLOTS



- Indicato per acque pulite
- Per resine a scambio ionico di piccolo diametro
- Per scambiatori con alte velocità di attraversamento
- Basse perdite di carico / Ampia superficie filtrante
- Suitable for clean water
- For ion exchange resins with low bead size
- For exchanger with high flow rate
- Low pressure loss / High filtering area

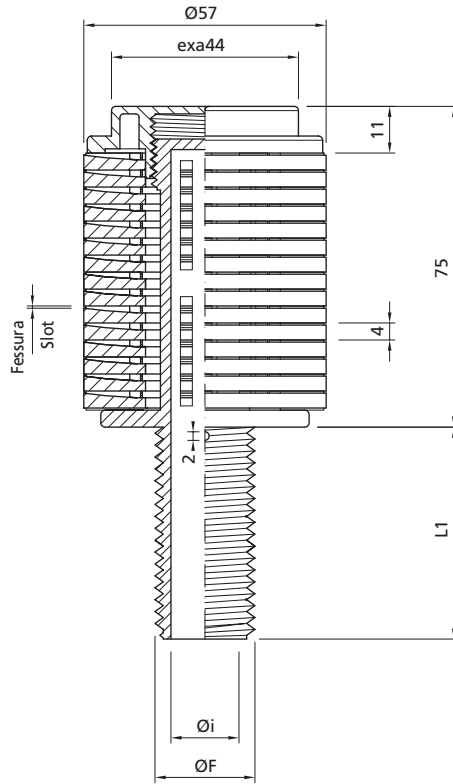

Tipo Type	Fessura Slot width mm	N. Fessure Slots No.	Sezione Area mm ²
D4.15	0,15	16	429
	0,25	16	715
	0,5	16	1430
	2	10	3570

Filetto Thread	ØF mm	Øi mm	Area codolo Stem area mm ²	L1 mm
15/16"W	23.5	17	225	30, 50

Materiale/Material: PP - PPFV - PVDF

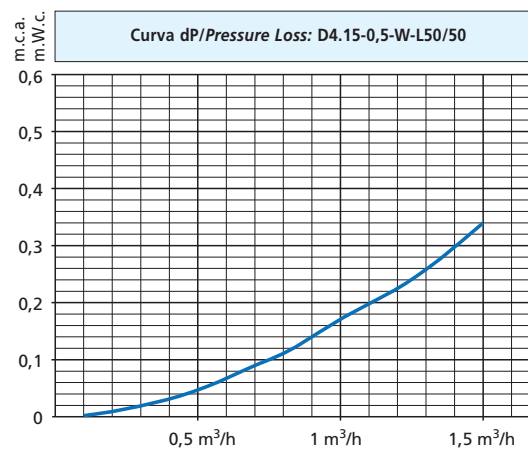
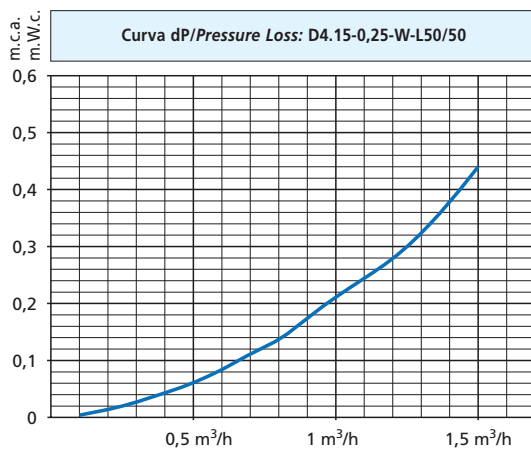

D3

UGELLI A FESSURE ORIZZONTALI FILTER NOZZLES WITH HORIZONTAL SLOTS



- Indicato per acque pulite
- Per resine a scambio ionico di piccolo diametro
- Per scambiatori con alte velocità di attraversamento
- Basse perdite di carico / Ampia superficie filtrante
- Molto robusto
- Piuttosto caro
- Suitable for clean water
- For ion exchange resins with low bead size
- For exchanger with high flow rate
- Low pressure loss / High filtering area
- Very strong
- Expensive

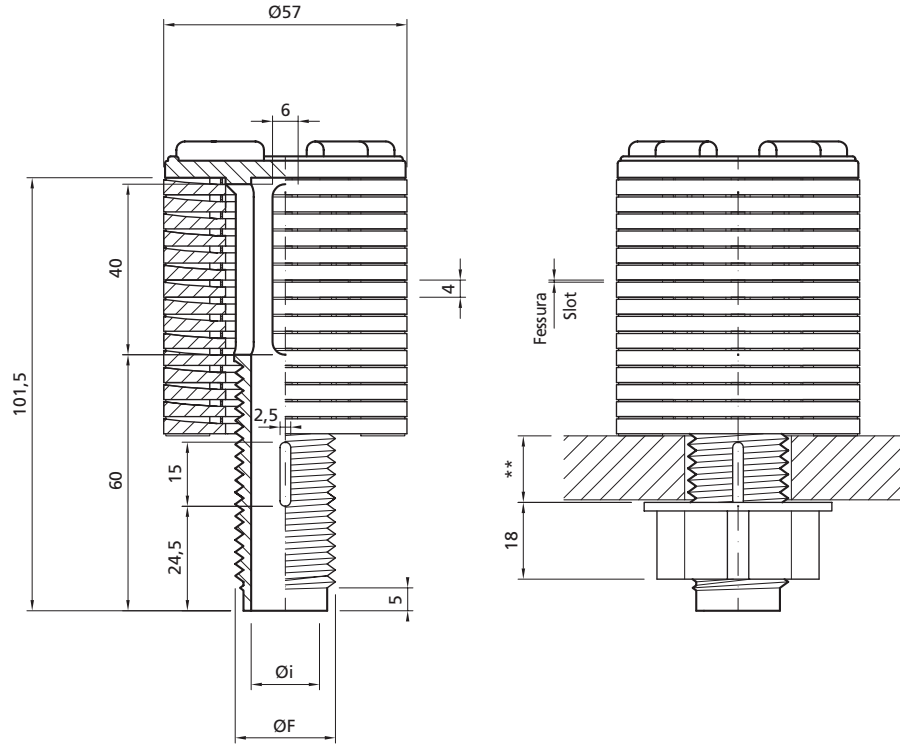

Tipo Type	Fessura Slot width mm	Sez/Fessure Area/Slot mm ²	N. Fessure Slots No. standard	Sezione std Area std mm ²
D3	0,15	26,8	18	483
	0,25	44,8	15	672
	0,5	89,5	14	1253
	2	358	11	1790

Filetto Thread	ØF mm	Øi mm	Area codolo Stem area mm ²	L1 mm mm
15/16"W	23,5	17	225	55

NOTE

- L'ugello viene fornito smontato: gambo, pacco dischi, dado.
- Il numero di dischetti è variabile.
- The nozzle is supplied disassembled: stem, disks, nut.
- Number of disks on request.

Materiale/Material: PP - PPFV - PVDF

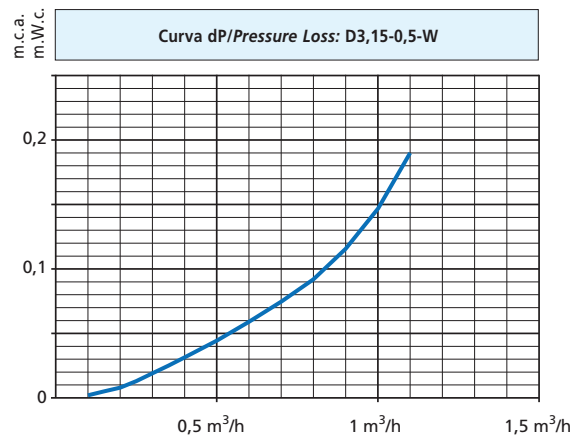
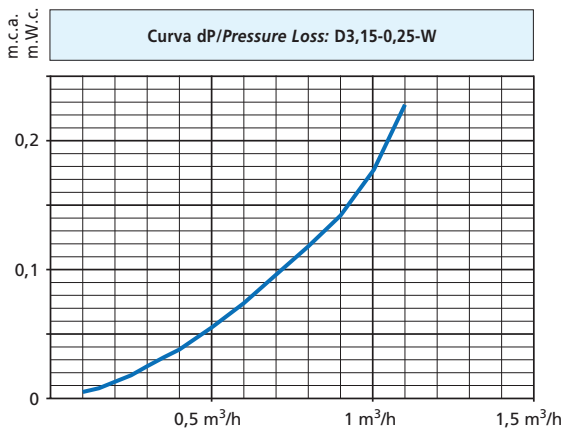

D9

UGELLI A FESSURE ORIZZONTALI FILTER NOZZLES WITH HORIZONTAL SLOTS



- Indicato per acque pulite
- Indicato per filtri trappola di piccole dimensioni
- Per scambiatori con alte velocità di attraversamento
- Basse perdite di carico / Ampia superficie filtrante
- Suitable for clean water
- Suitable for small size resin traps
- For exchangers with high flow rate
- Low pressure loss / High filtering area

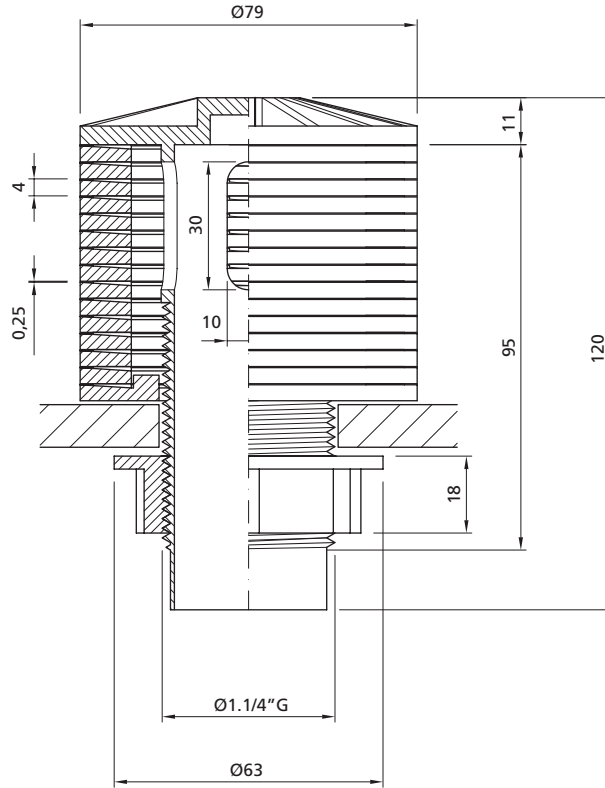

Tipo Type	Dischetti - Disks			Sezione Area mm ²
	Fessura Slot width mm	N. Fessure Slots No. mm	Sviluppo Lenght mm	
D9	0,25	15	248	930
	0,25	20	248	1240

Filetto Thread	Øe mm	Øi mm	Area codolo Stem area mm ²
1.1/4\"G	40.5	35	950

Materiale/Material: PP - PPFV - PVDF

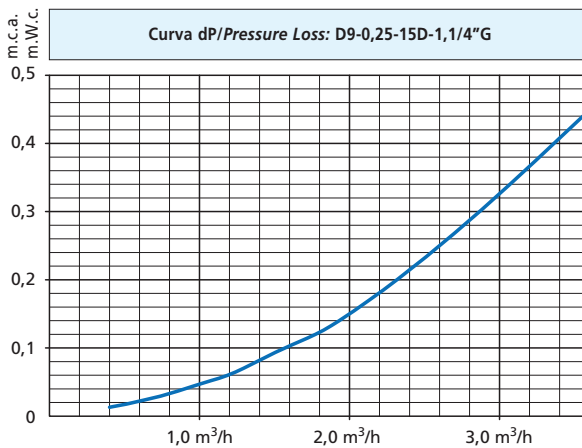



- Adatto per impieghi ad alte temperature (> 135° C)
- Particolarmente adatto per filtri a carboni con rigenerazione a vapore (alta temperatura/alta pressione)
- Suitable for high temperature applications (> 135° C)
- Suitable for GAC filter with steam regeneration (high temperature/high pressure)

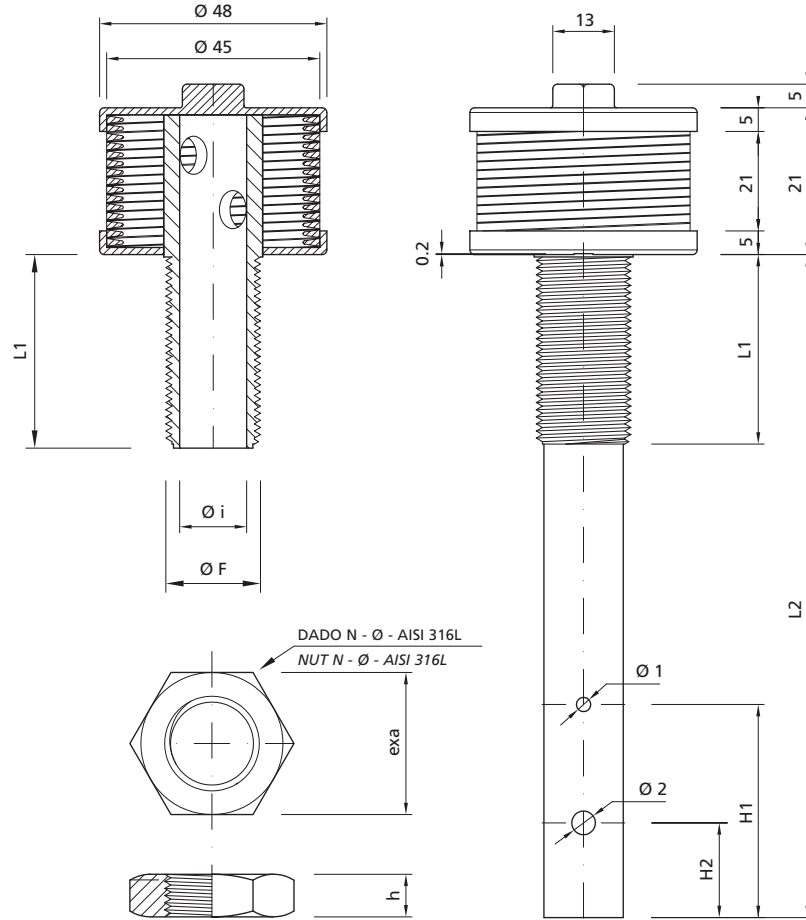

Tipo Type	Fessura Slot width mm	Sezione Area mm ²
HT	0,2	500
	0,3	740
	0,5	980

Filetto Thread	$\varnothing F$ mm	$\varnothing i$ mm	Area codolo Stem area mm ²	L1 mm	L2 mm
1/2"G	20,96	14	153	20	20
M20x1,5	19,70	14	153	20, 30, 45, ...	80, 100, 120, 140, ...
M24	23,70	17	226	20, 30, 45, ...	80, 100, 120, 140, ...

Materiale/Material: AISI 316 L - AISI 304 - Hastelloy

Note: È possibile realizzare ugelli a disegno le fessure sono disponibili in una gamma da 0,05 mm a 3,00 mm.

It is possible to make nozzles to customer specifications. A large range of slots is available, from 0,05 to 3,00 mm.

