



Dust suppression
FOG MAKER IN LOW PRESSURE

New!

IDROTECH®

**The flower
of nebulization**





Fog systems

FOG MAKER

GIRAFFA in low pressure - 10 bar (145 psi)



Detail of the cannon mouth of the industrial misting system GIRAFFA Fog maker, highlighting the two atomising nozzle-rings in action.



Detail of the fan installed on the industrial fog cannon GIRAFFA



Detail of the electrical panel of the industrial nebulizing system for dust suppression GIRAFFA



Detail of the pneumatic group of the hydraulic arm of the misting system for dust suppression GIRAFFA

Code	Model	Description
ZX.8503	GIRAFFA – FIXED VERSION 115	Industrial fogging system for dust suppression GIRAFFE - FIXED VERSION 115 with nebulizing module, column support 115 cm, water filter and control panel mounted on a concrete base.
ZX.8504	GIRAFFA – FIXED VERSION 300	Industrial fogging system for dust suppression GIRAFFE - FIXED VERSION 300 with nebulizing module, column support 300 cm, water filter and control panel mounted on a concrete base.
ZX.8505	GIRAFFA – FIXED VERSION 300P	Industrial fogging system for dust suppression GIRAFFE - FIXED VERSION 300P with nebulizing module, column support 300 cm, water filter and control panel mounted on a metal palletized base.
ZX.8506	GIRAFFA – MOBILE VERSION 300	Industrial fogging system for dust suppression GIRAFFE - MOBILE VERSION 300 with nebulizing module, column support 300 cm, water filter and control panel mounted on a base with wheels.
ZX.8507	GIRAFFA - FIXED HYDRAULIC VERSION	Industrial fogging system for dust suppression GIRAFFE - FIXED HYDRAULIC VERSION with nebulizing module, hydraulic column support, water filter and control panel mounted on a concrete base.
ZX.8508	GIRAFFA - FIXED HYDRAULIC VERSION+GE	Industrial fogging system for dust suppression GIRAFFE FIXED HYDRAULIC VERSION + GE with nebulizing module, hydraulic column support, water filter and control panel mounted on a fixed palletized base, equipped to receive a generator and an autopriming pump.



Fog systems

FOG MAKER

GIRAFFA in low pressure - 10 bar (145 psi)



With the dust suppression industrial system GIRAFFA, Idrotech has completed its range of misting systems. Thanks to a powerful fan and to the possibility to reach considerable heights (5 mt), water is sprayed in very fine particles covering a large area (about 25 meters) and achieves limits not easy to reach.

Advantages:

- Reduction of employed staff costs
- A more liveable work environment
- Reduction of wear and tear of the equipment
- Elimination of puddles and rivulets of water that can be sometimes polluted

Very positive impact on public administration and organs responsible for monitoring the environment.

Application fields: dust suppression in mines, quarries, steel plants, odour neutralization in garbage dumps, purification plants, contaminated areas, cooling in stadia, meeting areas, parks.

Technical features

- Power absorbed
- Power supply
- Protection degree

3 Kw
400V-50Hz
IP55

Mechanical features

- Rotation angle
- Elevation
- Fan diameter
- Rpm

320°
-20° +45°
410 mm
2800

Fluid dynamic features

- Flow range
- Noise

25 m
< 93 Lwa

Controls and automatisms

- ON / OFF switch
- Rotation right / left
- Up / down
- Pulse counter for rotation angle programming
- Fan start
- Start water supply (motor-pump/solenoid valves)
- Duty cycle remote control
- Operation light with buzzer

OPTIONAL

- Nozzles ring heating
- Night light
- ON/OFF and movement functions remote control

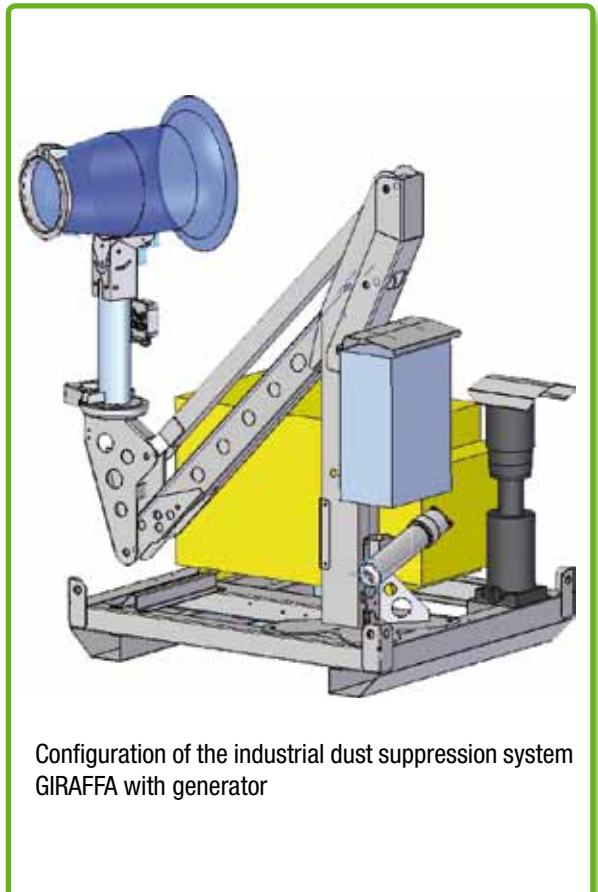

Configuration of the industrial dust suppression system GIRAFFA with generator

TERMS

- Delivery: **EX WORKS**
- Packing: **NOT INCLUDED**
- This catalogue replaces the previous one
- Technical features, prices, data, tables and figures are just indicative. Any change can be made by the company without prior notice.

IDROBASE®

IDROBASE s.r.l.

35010 BORGORICCO (PD) ITALY • Via dell'Industria, 25/A

Phone +39 049 9335903-4 • Fax +39 049 9335922

www.idrobase.com • idrobase@idrobase.com

Certificazione di qualità
Quality assured firm
有质量保证的企业
Сертификат качества
n° 9.160 - IDR3 - 31/10/1998
UNI ES ISO 9001:2000



Perfect Cool®

PERFECT COOL s.r.l.

47900 RIMINI (RN) ITALY • Via Cesare Pavese, 6

Phone +39 0541 395121 • Fax +39 0541 631674

www.perfectcool.it • info@perfectcool.it

IDROTECH®

IDROTECH s.r.l.

35010 BORGORICCO (PD) ITALY • Via dell'Industria, 25

Phone +39 049 9335136 • Fax +39 049 9335922

www.idrotech.com • idrotech@idrobase.com

Certificazione di qualità
Quality assured firm
有质量保证的企业
Сертификат качества
n° 9190 - IDRH - 11/02/2005
UNI EN ISO 9001:2000



Club dei Riparatori®

CLUB DEI RIPARATORI by IDROBASE s.r.l.

35010 BORGORICCO (PD) ITALY • Via dell'Industria, 25/A

Phone +39 049 9335908 • Fax +39 049 9335922

www.sparesclub.com • club@idrobase.com

Certificazione di qualità
Quality assured firm
有质量保证的企业
Сертификат качества
n° 9.190 - IDR3 - 31/10/1998
UNI ES ISO 9001:2000



HYDROEAST®

XINCHANG HYDROEAST CLEANING MACHINES LTD.

Exclusive representative: IDROBASE s.r.l.

35010 BORGORICCO (PD) ITALY • Via dell'Industria, 25/A

Phone +39 049 9335903-4 • Fax +39 049 9335922

www.hydroeast.cn • hydroeast@hydroeast.cn